



# SEALED WELL ELECTRIC TABLES WITH UNDERSHELF



SW-3E-240 Shown



Sealed Well with Drain

Item #: \_\_\_\_\_ Qty #: \_\_\_\_\_  
 Model #: \_\_\_\_\_  
 Project #: \_\_\_\_\_

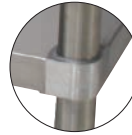

**Featuring as Standard:**  
**"THE PROVEN"**  
**ORIGINAL ADVANCE TABCO**  
**Adjustable Undershelf with Die Cast Leg Clamp**

## FEATURES:

- Stainless steel body and top
- Galvanized legs w/ adjustable bullet feet
- Galvanized undershelf
- Fiberglass insulation between each compartment
- Drains with gate valves per well
- Stainless steel 8" support shelf with removable 3/8" thick poly cutting board - Ships K.D.

## MATERIAL:

- TOP:** 20 gauge #302 stainless steel with die stamped pan openings. (11.875" x 20.062")
- BODY:** 22 gauge #430 stainless steel
- LEGS:** 1 5/8" diameter tubular galvanized steel
- 1" adjustable plastic bullet feet
- Stainless steel gussets
- UNDERSHELF:** Galvanized steel
- LINERS:** 20 Gauge stainless steel deep drawn with drain
- CUTTING BOARD:** White Thermoplastic
- CUTTING BOARD BRACKETS:** 16 gauge, #302 stainless steel

## ELECTRICAL:

- 120V units yield 640 Watts
- 208V/240V dual voltage units yield 825 Watts at 208V and 1100 Watts at 240V
- 6' electrical cord with plug
- Infinite control knobs
- Indicator lights



Model #	Length	Width*	# of Wells	Volts	Amps	Watts	NEMA Plug	Wt.	Cu. Ft.
SW-2E-120	A = 31-13/16"	30-5/8"	2	120	10.67	1280	5-20P	92 lbs.	28
SW-3E-120	B = 47-1/8"	30-5/8"	3	120	16	1920	5-20P	135 lbs.	41.32
SW-4E-120	C = 62-7/16"	30-5/8"	4	120	21.33	2560	L5-30P	230 lbs.	54.55
SW-2E-240	A = 31-13/16"	30-5/8"	2	208/240	7.94/9.16	1650/2200	6-20P	92 lbs.	28
SW-3E-240	B = 47-1/8"	30-5/8"	3	208/240	11.91/13.74	2475/3300	6-20P	135 lbs.	41.32
SW-4E-240	C = 62-7/16"	30-5/8"	4	208/240	15.88/18.32	3300/4400	L6-30P	230 lbs.	54.55
SW-5E-240	D = 77-3/4"	30-5/8"	5	208/240	19.85/22.90	4125/5500	L6-30P	270 lbs.	66.94

**\*Width Includes 8" Cutting Board**

**NOTE: Units are not designed to cook or heat frozen or refrigerated foods. Food placed in tables should already be hot, and the table will maintain the proper temperatures**

**NEMA PLUGS: Your plug will look like this...**



NEMA 5-20P



NEMA 6-20P



NEMA L5-30P

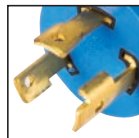

NEMA L6-30P

**NOTE: For international applications, plug may need to be replaced (by others) in field.**

## Stainless Steel Legs & Undershelf Upgrade

2 Well Table	3 Well Table	4 Well Table	5 Well Table
SU-23A	SU-23B	SU-23C	SU-23D



**Customer Service Available To Assist You 1-800-645-3166 8:30 am - 7:00 pm E.S.T.**

For Orders:

Email: [customer@advancetabco.com](mailto:customer@advancetabco.com) or Fax To: 631-242-6900

For Smart Fabrication™ Quotes:

Email: [smartfab@advancetabco.com](mailto:smartfab@advancetabco.com) or Fax To: 631-586-2933

# DIMENSIONS and SPECIFICATIONS

TOL ± .125"

ALL DIMENSIONS ARE TYPICAL

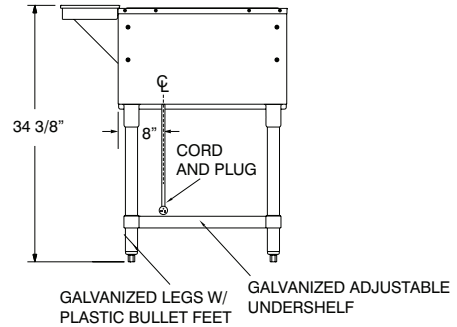
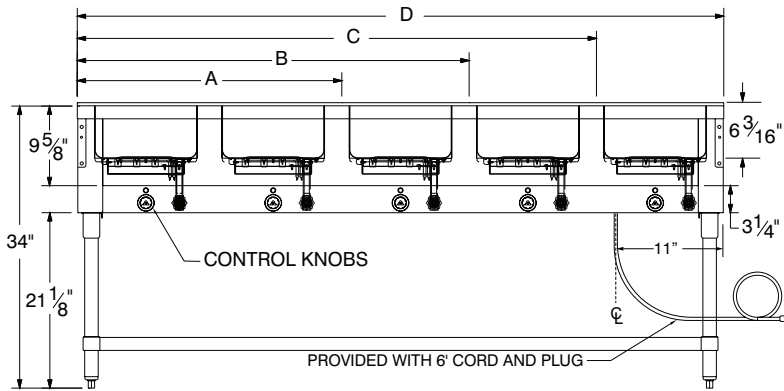
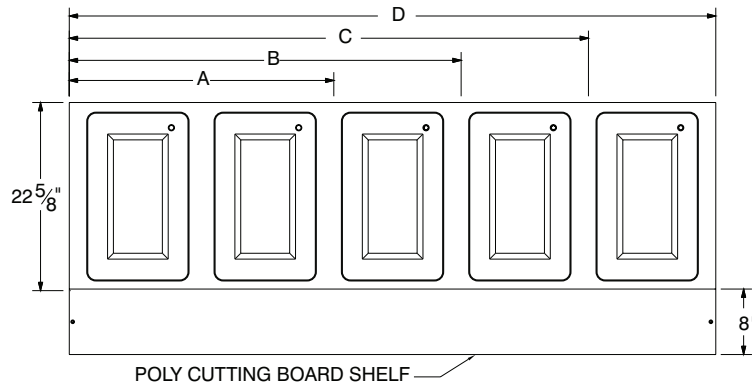

## Food Table Shelving, Options & Accessories

Visit our website for additional Food Table Accessories



19-1/4" Height

**10" Wide Buffet Shelf**  
with Built-In Food Shield

Model	Length	Approx Wt.	Cu. Ft.
TBS-2	31-13/16"	34 lbs.	2
TBS-3	47-1/8"	42 lbs.	3
TBS-4	62-7/16"	47 lbs.	4
TBS-5	77-3/4"	55 lbs.	4



**Acrylic Side Panels**  
for Buffet Shelf

Add side panels to meet additional NSF requirements (2 panels per side)

TBP-1 **One Side**  
TBP-2 **Two Sides**

Field Installation Available



15" Height

**10" Wide Serving Shelf**  
with Built-In Food Shield

Model	Length	Approx Wt.	Cu. Ft.
TSS-2	31-13/16"	18 lbs.	2
TSS-3	47-1/8"	23 lbs.	3
TSS-4	62-7/16"	30 lbs.	4
TSS-5	77-3/4"	35 lbs.	4

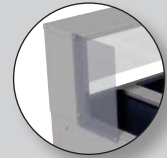

**Acrylic Side Panel**  
for Serving Shelf

Add side panels to meet additional NSF requirements (1 panel per side)

TSP-1 **One Side**  
TSP-2 **Two Sides**

Field Installation Available

**SU-25S** Add Casters to Food Units with Undershelf (Includes 4 -5" Swivel Casters, 2 w/ Brakes & Legs That Maintain Height)

**SU-25** Add Casters to Food Units with Undershelf (For Units Built Before Oct. 2015. Includes 4 -5" Swivel Casters, 2 w/ Brakes.)

**SU-90** Automatically fills & maintains water level. For DISW, DISLSW, SW & HDSW Series. Requires Manifold Drain Assembly (Except HDSW series).

**TCB-OMIT** Remove Poly Cutting Board

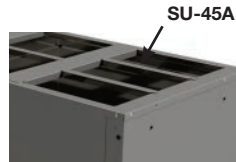

**SU-45A** 12" x 1" Adapter Bar  
**SU-45B** 20" x 3" Adapter Bar



Manifold Drain Shown (-M)

**-T** Thermostatic Control (Per Well)  
**-M** Manifold Drains (Per Well)

